

Subsurface Mooring Monitoring Beacons

SMM 2000 X and SMM 6000 X

User Manual

Version 2.0

March 2011

**SiS Sensoren Instrumente Systeme GmbH
Mühlenkoppel 12
24222 Schwentinental
Germany
<http://www.sis-germany.com>**

Contents

- 1. General Information.....2
 - 1.1 Description.....2
 - 1.2 Switch Mode Power Supply.....2
- 2. Operating Instructions.....3
 - 2.1 Choosing Batteries for your Application.....3
 - 2.2 Opening the Housing.....3
 - 2.3 Insertion of Batteries.....3
 - 2.4 Replacement of Moisture Absorbent.....4
- 3. Principle of Operation.....4
 - 3.1 SMM Operation.....4
 - 3.2 CLS Argos Localisation Service.....4
 - 3.3 Admission to the Argos System.....4
- 4. Maintenance.....5
 - 4.1 Maintenance Notes.....5
 - 4.2 Maintenance Parts and Tools.....5
 - 4.3 General Disassembly.....5
 - 4.4 Replacement of Main Housing O-rings.....5
 - 4.5 Replacement of Main Housing Screws.....6
 - 4.6 Pressure Switch Replacement.....6
 - 4.7 General Assembly.....6
- 5. Appendix.....7
 - 5.1 Technical Specification.....7
 - 5.2 Warranty and Support.....7

List of Figures

- Figure 1: SMM 2000 / 6000 X Dimensions.....2
- Figure 2: Membrane.....6

1. General Information

1.1 Description

The SMM 2000 / 6000 X consists of a titanium tube closed by end caps. The upper cap holds the antenna and the protection cage which is transparent to UHF radiation. The cage has openings for the outflow of seawater and a cover for the protection of snow and ice.

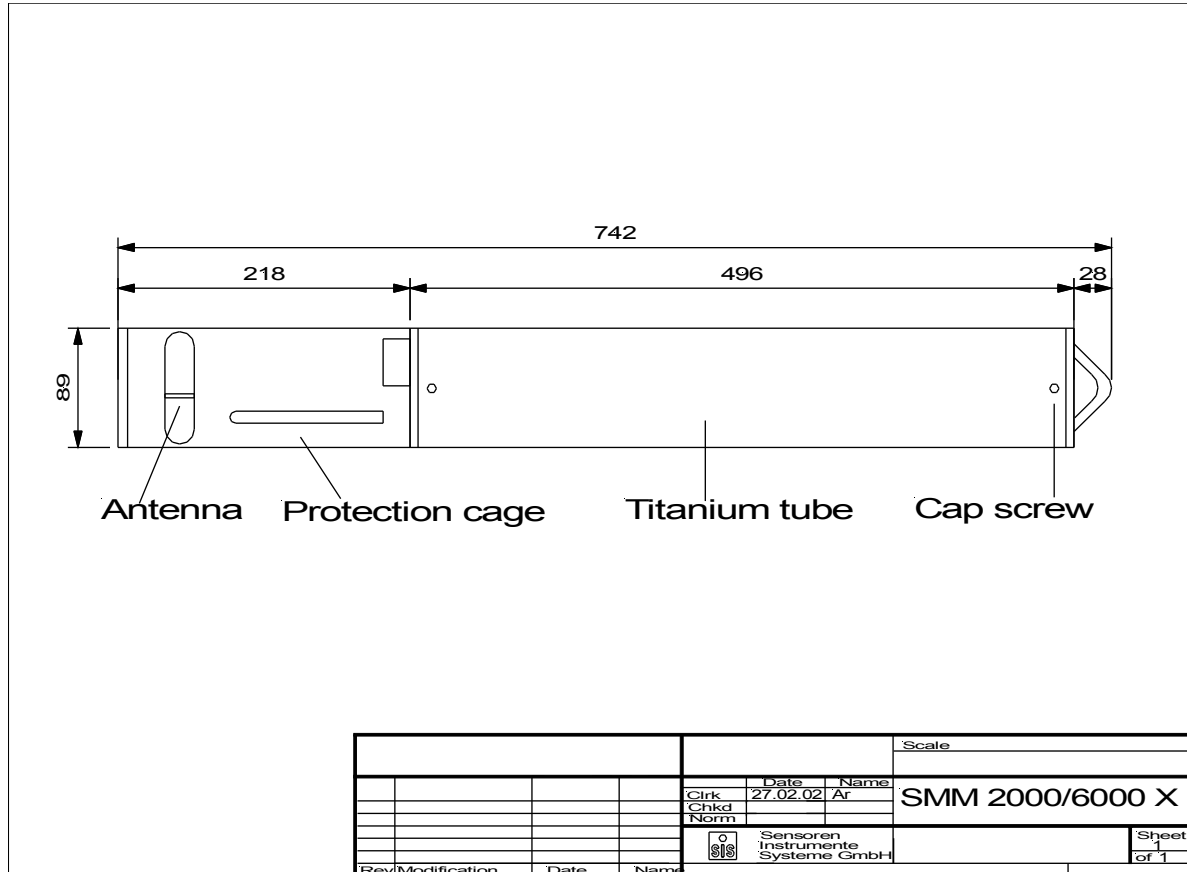

Figure 1: SMM 2000 / 6000 X Dimensions

Inside the housing is a battery holder for two bundles of 5 batteries each in series. The batteries power the transmitter (PTT) via a switch mode power supply. The power is switched on by a pressure switch inside the upper cap. The switch is separated by a membrane from seawater. The pressure transmission is done by silicon oil.

At the lower cap you will find a bow. This bow is for opening the housing in case of battery replacement. You must not use this bow for mooring of the instrument.

The depth capability of the SMM 2000 X is 2000 m and that for the SMM 6000 X is 6000m.

Don't use the SMM 2000 / 6000 X in the euphotic zone up to 200 m, for the transmission might be interfered by biofouling. There is a shallow water version available with protected dry antenna (SMM 500 X).

1.2 Switch Mode Power Supply

All SMM X series instruments contain an internal switch mode power supply to allow usage of a wide range of battery types. The supply power is buffered to reduce peak current sourced from the batteries. This allows usage of batteries which can only source low currents and increases operation time by getting higher effective battery capacities.

2. Operating Instructions

2.1 Choosing Batteries for your Application

The cell voltage has to be between 0.8 V and 3.7 V allowing the usage of lithium batteries, alkaline batteries or nickel-metal hydride (NiMH) accumulators as well. For long term moorings in cold environment we recommend to use high quality lithium cells due to their high capacity and low self-discharge rate.

For calculation of battery lifetime use the average power consumption when surfaced. Divide the energy content of the 10 or 5 batteries by the mean power consumption (35 mW) of the beacon. The table shows typical transmission life times for different battery types when using 10 batteries:

Temperature	Li-SOCl ₂	Li-MnO ₂	Alkaline	NiMH
20 °C	557 days	475 days	230 days	30 days
0 °C	550 days	450 days	190 days	28 days
-30 °C	320 days	390 days	not applicable	not applicable

Li-SoCl₂ battery: Saft LSH20, Lithium-thionyl chloride, Size D, Capacity 13 Ah
Li-MnO₂ battery: Saft LM33550, Lithium-manganese dioxide, Size D, Capacity 13 Ah
Alkaline battery: Philips LR20, Green Alkaline, Size D, Capacity 13.2 Ah
NiMH battery: Duracell HR20, Nickel-metal hydride, Size D, Capacity 2.2 Ah

Please halve the times when using only 5 batteries.

The transmission time is reduced by self-discharge during the mooring time. The table shows typical shelf life times (storage time at 20 °C until the battery has 80% of its initial energy) for different battery types.

Li-SOCl ₂	Li-MnO ₂ , Li-SO ₂	Alkaline	NiCd	NiMH
10 – 20 years	10 years	5 - 7 years	80 days	18 - 20 days

NiCd (nickel-cadmium) accumulators are disallowed in the EC but are mentioned for comparison. The self-discharge rate is temperature dependant. With NiMH, the shelf life time is significantly longer at lower temperatures.

NOTE:

Insert only absolute identical cells (manufacturer, type, capacity, age, discharge state).

2.2 Opening the Housing

You open the housing by removing the end caps. The caps are fastened by two hexagon socket screws each. For opening please screw clockwise thereby turning in the screw into the cap. This paradox solution - screwing tight for opening and screwing loose for fastening - has the advantage that you won't lose the small screws. When the instrument is opened screws and end cap build one unit. You then may pull out the cap.

The inner part is fastened at the upper cap. Normally you don't have to remove the instrument from the housing. One of the screws of the upper cap is filled with epoxy resin. So you can't open inadvertently. A tight connection of the upper screws with the tube is necessary because a good electrical connection between cap and tube is important, for the tube is the ground plane for the antenna.

2.3 Insertion of Batteries

Don't open the housing by removing the upper cap. Open the housing by removing the lower

one.

Put the instrument upside down on the floor. Place a rail through the upper opening of the antenna cage and fasten by getting up on the rail. Be sure not to interfere with the antenna inside the cage. Place a rod (e.g. screw driver) through the bow at the now upper cap and pull out the end cap.

You will now find a PVC disc, take it out and you will see two tubings in a acetal resin (POM) block and one contact pin. Put 5 pieces D type batteries into each tube, oriented with the minus terminal in direction of the antenna.

If you want the instrument to operate after insertion of batteries close the housing by insertion of the end cap.

In case you only want to insert batteries but later on want to operate, please place the PVC disk for isolation between batteries and cap.

2.4 Replacement of Moisture Absorbent

The printed circuit boards are protected by coating, but condensation of humidity should be avoided. When leaving the factory, the instrument is filled with dry argon gas and a small pack with moisture absorbent is placed in a slot between the battery holder and the titanium housing at the lower end. We recommend to fill with dry gas or replace the moisture absorbent after every opening of the housing. Normally together with battery replacement. With the instrument we deliver some packs with moisture absorbent sealed in a plastic bag.

3. Principle of Operation

3.1 SMM Operation

The SMM 2000 and 6000 X subsurface mooring monitoring beacons go down with the mooring up to 2000 and 6000 m respectively with the PTT turned off by the pressure switch. If the mooring line should break, or when the mooring is being recovered, the PTT will switch on as it approaches the surface. In the first case, the beacon will transmit for the lifetime of the batteries in the second, the beacon is manually switched off after recovery.

3.2 CLS Argos Localisation Service

CLS Service Argos has developed a special service for monitoring the status of the moorings. An alarm state is set upon reception of the signal by an orbiting satellite and recognition and processing at a ground centre. A warning that the mooring line has surfaced, with its position, will be sent to the user by email or fax. Thereafter each satellite pass will result in another location and another alarm message until a specified maximum number of messages has been sent. Generation of alarm messages may be cancelled by the user at any time. Users always may access data on-line via web interface and Telnet.

3.3 Admission to the Argos System

The user must fill out some forms and forward it to the Argos User Office:

- Argos System Use Agreement
- Silent Argos Monitor Welcome Pack
- ID number request

Please see the Argos documentation for detailed information.

4. Maintenance

4.1 Maintenance Notes

The replacement of the wearing parts, described below, should only be done by qualified technical personnel. Inexpert handling can produce serious damage.

4.2 Maintenance Parts and Tools

Requires (depends on the parts to be replaced):

- SMM 2000 / 6000 pressure switch spare part kit with:
 - 1 x SMM 2000 / 6000 pressure switch (adjusted to 25 - 35 m)
 - 1 x O-ring, 15.6 x 1.78, 90 shore
 - 1 x O-ring, 4.47 x 1.78, 90 shore
 - 1 x silicon oil (AK 100, Wacker Chemie, FRG)
 - 1 x membrane (60EPDM/266, Carl Freudenberg, Reichelsheim, FRG)
 - 4 x slotted countersunk head screw, DIN 963, M3x8, titanium
- SMM 2000 / 6000 housing O-rings
 - 4 x O-ring, 69.44 x 3.53, 90 shore
- SMM 2000 / 6000 housing screws
 - 4 x titanium screw
- silicon paste (e.g. TEGO-Silikonpaste S 200, Th. Goldschmidt AG, Essen, FRG) or silicon-based O-ring lubrication (e.g. Super-O-Lube, Parker)
- cleaning cloth (not napped)
- screw driver for M3 screws (for pressure switch plate)
- screw driver for M4 screws (for pressure switch connection)
- 6 mm tubular socket wrench (for antenna cable)
- 24 mm tubular socket wrench (for pressure switch)
- 3 mm hex driver (for antenna cage screws)
- 4 mm hex driver (for housing screws)

4.3 General Disassembly

- Turn the two hexagon socket screws at the battery cap clockwise into the cap and remove the battery cap.
- Turn the two hexagon socket screws at the antenna dome clockwise into the dome and remove the titanium housing.
- Detach the antenna cable from the ARGOS transmitter.
- Remove the two screws that connect the main part to the antenna cap.
- Detach the cables from the pressure switch.

4.4 Replacement of Main Housing O-rings

- Remove the O-rings from the caps by using a small screw driver. Be carefully to make no marks in the grooves.
- Clean the grooves with the dry cleaning cloth.
- Check the grooves for marks. If there are any marks, replacement of the caps is necessary.
- Check the new O-rings for damage.
- Grease the O-rings very slightly with the silicon paste. There should only be a thin film on the rings.
- Place the new O-rings into the grooves.

4.5 Replacement of Main Housing Screws

- Remove the old screws from the caps and replace them by the new ones.

4.6 Pressure Switch Replacement

- Remove the antenna protection cage by loosening the screws from the titanium cap.
- Remove the antenna.
- Unscrew the four countersunk head screws holding the plate.
- Remove the plate and the membrane and pour out the oil.
- Turn around the cap and loosen the old pressure switch with the tubular socket wrench (right-handed thread).
- Clean the O-ring grooves.
- Slightly grease the new O-rings and fit them in the grooves of the new pressure switch.
- Fit the new pressure switch (don't screw too tight).
- Turn around the housing and fill the hole nearly up to the border with new oil from the spare parts kit. Ensure that the hole is totally filled with oil; there should be no air bubbles.
- Prepare the new membrane according to Figure 2 and insert the membrane.
- Refit the plate and fasten it with the four screws.
- Refit the antenna and the protection cage.

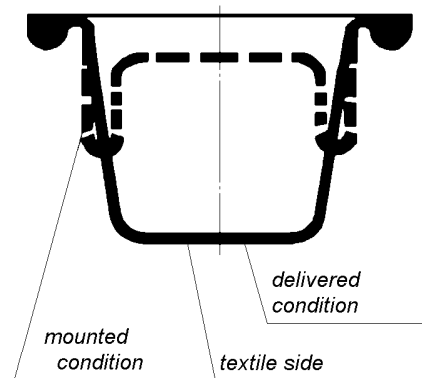

Figure 2: Membrane

4.7 General Assembly

- Pull the antenna cable through the hole of the main part.
- Fasten the cables at the pressure switch.
- Refit the antenna cap to the main part.
- Connect the antenna cable to the ARGOS transmitter.
- Refit the main housing to the antenna cap. The battery symbol on the main housing must point to the battery cap side.
- Refit the battery cap.

5. Appendix

5.1 Technical Specification

Mooring depth	2000 or 6000 m
Pressure switch threshold	25 - 35 m
Dimensions (l x d)	742 x 89 mm
Mass without batteries	6.7 kg
Displacement	3.1 dm ³
Power Supply	5 or 10 pcs. D cells resp.
Battery Types	NiMH, Alkaline, Lithium (Li-SO ₂ , Li-MnO ₂ , and Li-SOCl ₂)
Battery cell voltage	0.8 V – 3.7 V
Peak supply current	100 mA
Average power consumption when surfaced	35 mW
Mooring life (1)	depending on the self-discharge of the used batteries
Transmission life (1)	depending on the used batteries
Transmitter manufacturer	Elta
Transmitter model	HAL2
Output power	33 dBm (2 W)
Message length (2)	32 bits
Repetition rate (3)	90 seconds
Transmit frequency	401.630 MHz

Notes:

1. See chapter 2.1, "Choosing Batteries for your Application", for detailed information.
2. The SMM did not send any user data. Therefore, the message length is set to the minimum value of 32 bits. With Elta HAL2 transmitters, a prefix byte (typ. 25 hex, with 20-bit ID only), temperature (°C), supply voltage (mV / 64) and power indication (mV / 4) are send.
3. The default repetition rate is 90 seconds (recommended by Argos for SMM service). Other rates (e.g. 60 seconds) can be programmed upon request. For the conditioning of the power supply please notice that the **first** transmission will need about 100 to 150 seconds to occur.

5.2 Warranty and Support

SiS warrants this instrument to the original purchaser to be free of defects in material or manufacturing for a period of two years. Liability is limited to repair or replacement of the defective part which will be done without charge if the instrument is returned to our factory prepaid. This warranty does not apply to instruments subjected to misuse or tampering. No responsibility or warranty for consequential damage is included in the sale of this instrument.

SiS - Sensoren Instrumente Systeme GmbH
Mühlenkoppel 12, D-24222 Schwentinental, Germany
Tel.: +49-431-79972-0
Fax: +49-431-79972-11
Email: info@sis-germany.com
WWW: <http://www.sis-germany.com>