

Subsurface Mooring Monitoring Beacon

SMM 500 X

User Manual

Version 2.0

March 2011

**SiS Sensoren Instrumente Systeme GmbH
Mühlenkoppel 12
24222 Schwentinental
Germany
<http://www.sis-germany.com>**

Contents

- 1. General Information.....2**
 - 1.1 Description.....2**
 - 1.2 Switch Mode Power Supply.....2**
- 2. Operating Instructions.....3**
 - 2.1 Choosing Batteries for your Application.....3**
 - 2.2 Opening the Housing.....3**
 - 2.3 Insertion of Batteries.....3**
 - 2.4 Replacement of Moisture Absorbent.....4**
- 3. Principle of Operation.....4**
 - 3.1 SMM Operation.....4**
 - 3.2 CLS Argos Localisation Service.....4**
 - 3.3 Admission to the Argos System.....4**
- 4. Maintenance.....5**
 - 4.1 Maintenance Notes.....5**
 - 4.2 Maintenance Parts and Tools.....5**
 - 4.3 General Disassembly.....5**
 - 4.4 Replacement of Main Housing O-rings.....5**
 - 4.5 Replacement of Pressure Switch.....5**
 - 4.6 General Assembly.....6**
- 5. Appendix.....7**
 - 5.1 Technical Specification.....7**
 - 5.2 Warranty and Support.....7**

List of Figures

- Figure 1: SMM 500 X Dimensions.....2
- Figure 2: Membrane.....6

1. General Information

1.1 Description

The SMM 500 X consists of a titanium tube closed by end caps made of acetal resin (POM). The bigger upper cap contains the antenna.

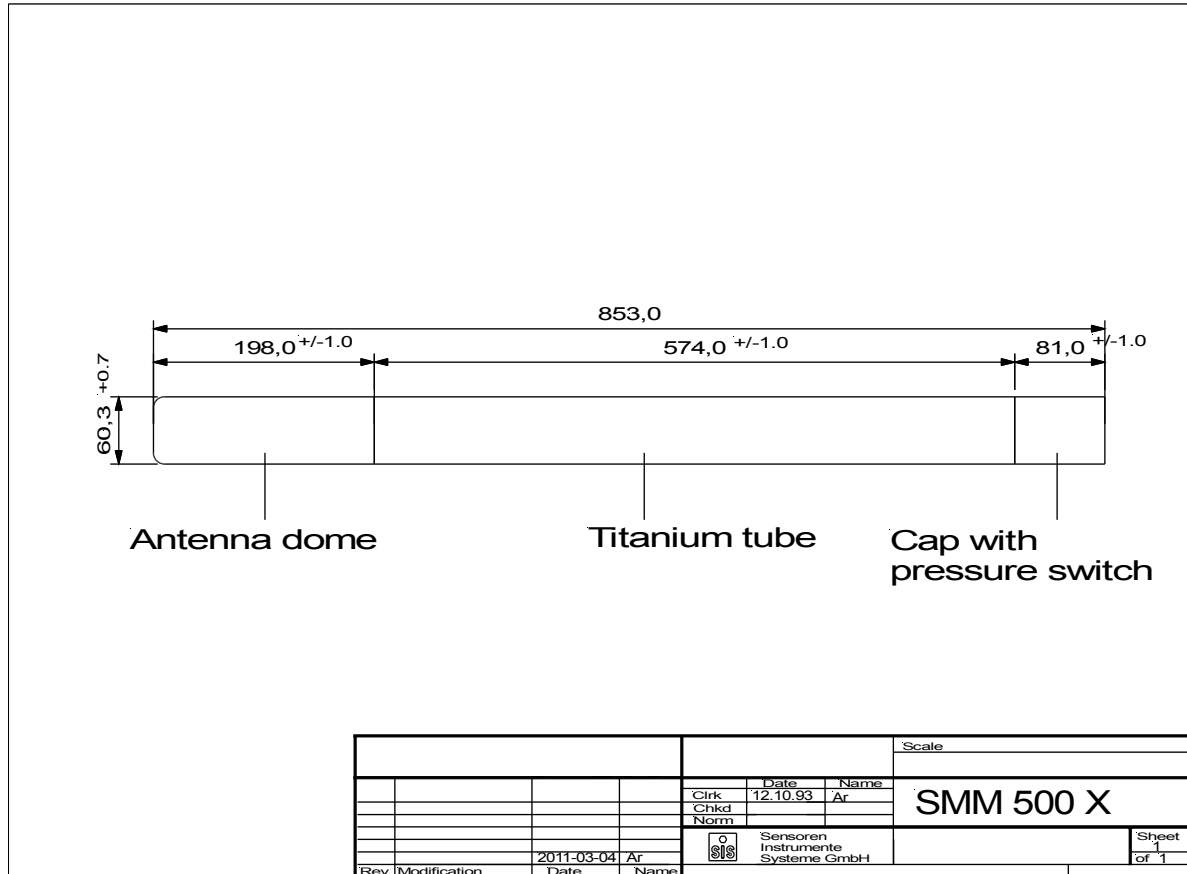

Figure 1: SMM 500 X Dimensions

Inside the housing is a battery holder for one bundle of 5 batteries in series. The batteries power the transmitter (PTT) via a switch mode power supply. The power is switched on by a pressure switch inside the lower cap. The switch is separated by a membrane from seawater. The pressure transmission is done by silicon oil.

The SMM 500 X is for shallow water moorings up to 500 m. If you need a SMM for deep sea moorings please use the SMM 2000 X or SMM 6000 X series.

1.2 Switch Mode Power Supply

All SMM X series instruments contain an internal switch mode power supply to allow usage of a wide range of battery types. The supply power is buffered to reduce peak current sourced from the batteries. This allows usage of batteries which can only source low currents and increases operation time by getting higher effective battery capacities.

2. Operating Instructions

2.1 Choosing Batteries for your Application

The cell voltage has to be between 0.8 V and 3.7 V allowing the usage of lithium batteries, alkaline batteries or nickel-metal hydride (NiMH) accumulators as well. For long term moorings in cold environment we recommend to use high quality lithium cells due to their high capacity and low self-discharge rate.

For calculation of battery lifetime use the average power consumption when surfaced. Divide the energy content of the 5 batteries by the mean power consumption (35 mW) of the beacon. The table shows typical transmission life times for different battery types:

Temperature	Li-SOCl ₂	Li-MnO ₂	Alkaline	NiMH
20 °C	277 days	237 days	115 days	15 days
0 °C	275 days	225 days	95 days	14 days
-30 °C	160 days	195 days	not applicable	not applicable

Li-SoCl₂ battery: Saft LSH20, Lithium-thionyl chloride, Size D, Capacity 13 Ah
Li-MnO₂ battery: Saft LM33550, Lithium-manganese dioxide, Size D, Capacity 13 Ah
Alkaline battery: Philips LR20, Green Alkaline, Size D, Capacity 13.2 Ah
NiMH battery: Duracell HR20, Nickel-metal hydride, Size D, Capacity 2.2 Ah

The transmission time is reduced by self-discharge during the mooring time. The table shows typical shelf life times (storage time at 20 °C until the battery has 80% of its initial energy) for different battery types.

Li-SOCl ₂	Li-MnO ₂ , Li-SO ₂	Alkaline	NiCd	NiMH
10 – 20 years	10 years	5 - 7 years	80 days	18 - 20 days

NiCd (nickel-cadmium) accumulators are disallowed in the EC but are mentioned for comparison. The self-discharge rate is temperature dependant. With NiMH, the shelf life time is significantly longer at lower temperatures.

NOTE:

Insert only absolute identical cells (manufacturer, type, capacity, age, discharge state).

2.2 Opening the Housing

You open the housing by removing the end caps. The caps are fastened with the tube by threads. For opening please screw the lower cap anti-clockwise thereby turning the cap out of the tube.

The inner part is fastened at the upper cap. Normally you don't have to remove the instrument from the housing.

2.3 Insertion of Batteries

Don't open the housing by removing the upper cap. Open the housing by removing the lower cap.

You will now find a PVC disc, take it out and you will see a tube in a PVC block. Put 5 pieces D type batteries into the tube oriented with the plus terminal in direction of the antenna cap.

If you want the instrument to operate after insertion of batteries, close the housing by screwing in the lower cap clockwise.

In case you only want to insert batteries but later on want to operate, please place the PVC disk for isolation between batteries and cap.

2.4 Replacement of Moisture Absorbent

The printed circuit boards are protected by coating, but condensation of humidity should be avoided. When leaving the factory, the instrument is filled with dry argon gas and four small packs with moisture absorbent are placed in slots between the battery holder and the titanium housing at the lower end. We recommend filling with dry gas or replacing the moisture absorbent after every opening of the housing. Normally together with battery replacement. With the instrument we deliver some packs with moisture absorbent sealed in a plastic bag.

3. Principle of Operation

3.1 SMM Operation

The SMM 500 X subsurface mooring monitoring beacons go down with the mooring up to 500 m with the PTT cut off by the pressure switch. If the mooring line should break, or when the mooring is being recovered, the PTT will switch on as it approaches the surface. In the first case, the beacon will transmit for the lifetime of the batteries in the second, the beacon is manually switched off after recovery.

3.2 CLS Argos Localisation Service

CLS Service Argos has developed a special service for monitoring the status of the moorings. An alarm state is set upon reception of the signal by an orbiting satellite and recognition and processing at a ground centre. A warning that the mooring has surfaced, with its position, will be sent to the user by email or fax. Thereafter each satellite pass will result in another location and another alarm message until a specified maximum number of messages has been sent. Generation of alarm messages may be cancelled by the user at any time. Users always may access data on-line via web interface and Telnet.

3.3 Admission to the Argos System

The user must fill out some forms and forward it to the Argos User Office:

- Argos System Use Agreement
- Silent Argos Monitor Welcome Pack
- ID number request

Please see the Argos documentation for detailed information.

4. Maintenance

4.1 Maintenance Notes

The replacement of the wearing parts, described below, should only be done by qualified technical personnel. Inexpert handling can produce serious damage.

4.2 Maintenance Parts and Tools

Requires (depends on the parts to be replaced):

- SMM 500 pressure switch spare part kit with:
 - 1 x SMM 500 pressure switch (adjusted to 3 - 5 m)
 - 1 x O-ring, 15.6 x 1.78, 90 shore
 - 1 x O-ring, 4.47 x 1.78, 90 shore
 - 1 x silicon oil (AK 100, Wacker Chemie, FRG)
 - 1 x membrane (60EPDM/266, Carl Freudenberg, Reichelsheim, FRG)
 - 4 x slotted countersunk head screw, DIN 963, M3x8, titanium
- SMM 500 housing O-rings
 - 4 x O-ring, 52.07 x 2.62, 90 shore
- silicon paste (e.g. TEGO-Silikonpaste S 200, Th. Goldschmidt AG, Essen, FRG) or silicon-based O-ring lubrication (e.g. Super-O-Lube, Parker)
- cleaning cloth (not napped)
- screw driver for M3 screws (for pressure switch plate)
- screw driver for M4 screws (for pressure switch connection)
- small screw driver
- thin tape
- 24 mm tubular socket wrench (for pressure switch)

4.3 General Disassembly

- Remove the pressure switch housing.
- Remove the antenna dome housing.

4.4 Replacement of Main Housing O-rings

- Remove the O-rings from the housings with the small screw driver. Be carefully to make no marks in the grooves.
- Clean the O-ring grooves with the dry cleaning cloth.
- Check the grooves for marks. If there are any marks, replacement of the antenna dome or pressure switch housing is necessary.
- Cover up the ring followers at the housings with the tape.
- Check the new O-rings for damage.
- Grease the O-rings very slightly with the silicon paste. There should only be a thin film on the rings.
- Put a piece of paper around the battery tube and slide two O-rings over the paper.
- Push the paper with the O-rings over the battery tube and the ring follower and fit the O-rings in the grooves of the antenna dome.
- Fit the other two O-rings in the grooves of the pressure switch housing.
- Remove the tape from the ring followers.

4.5 Replacement of Pressure Switch

- Unscrew the slotted countersunk head screw from the ring follower.

- Unscrew the ring follower (right-handed thread).
- Detach the cables from the pressure switch.
- Turn around the housing and unscrew the four countersunk head screws at the plate.
- Remove the plate and the old membrane and pour out the oil.
- Turn around the housing and loosen the pressure switch with the tubular socket wrench (right-handed thread).
- Remove the old O-rings from the pressure switch.
- Clean the grooves.
- Slightly grease the new O-rings and fit them in the grooves of the pressure switch.
- Refit the pressure switch or replace by a new one (don't screw too tight).
- Turn around the housing and fill the hole nearly up to the border with new oil from the spare parts kit.
- Prepare the new membrane according to Figure 2 and insert the membrane.
- Refit the plate and screw it with the four new screws from the spare parts kit.
- Fasten the cables at the pressure switch and turn the ring follower until the cables are untwisted.
- Turn the ring follower three turns to the left, insert and fasten it (approx. 6 turns right, not too tight).
- Turn the ring follower until the screw hole is in alignment with the thread in the housing.
- Insert and fasten the slotted countersunk head screw. If the screw turns sluggish, turn the ring follower a little bit.

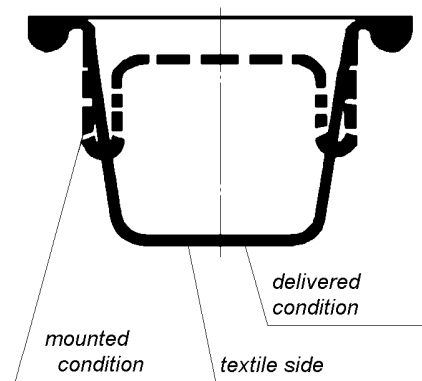

Figure 2: Membrane

4.6 General Assembly

- Reassemble the pressure switch housing at the end with the battery sign and the antenna dome housing at the other side.

5. Appendix

5.1 Technical Specification

Mooring depth	500 m
Pressure switch threshold	3 - 5 m
Dimensions (l x d)	853 x 60.3 mm
Mass without batteries	3.8 kg
Displacement	2.4 dm ³
Power Supply	5 pcs. D cells
Battery Types	NiMH, Alkaline, Lithium, or Lithium Thionyl Chloride
Battery cell voltage	0.8 V – 3.7 V
Peak supply current	100 mA
Average power consumption when surfaced	35 mW
Mooring life (1)	depending on the self-discharge of the used batteries
Mooring life in euphotic zone	up to 6 months
Transmission life (1)	depending on the used batteries
Transmitter manufacturer	Elta
Transmitter model	HAL2
Output power	33 dBm (2 W)
Message Length (2)	32 bits
Repetition rate (3)	90 seconds
Transmit frequency	410.630 MHz

Notes:

1. See chapter 2.1, “Choosing Batteries for your Application”, for detailed information.
2. The SMM did not send any user data. Therefore, the message length is set to the minimum value of 32 bits. With Elta HAL2 transmitters, a prefix byte (typ. 25 hex, with 20-bit ID only), temperature (°C), supply voltage (mV / 64) and power indication (mV / 4) are send.
3. The default repetition rate is 90 seconds (recommended by Argos). Other rates (e.g. 60 seconds) can be programmed upon request.

5.2 Warranty and Support

SiS warrants this instrument to the original purchaser to be free of defects in material or manufacturing for a period of two years. Liability is limited to repair or replacement of the defective part which will be done without charge if the instrument is returned to our factory prepaid. This warranty does not apply to instruments subjected to misuse or tampering. No responsibility or warranty for consequential damage is included in the sale of this instrument.

SiS - Sensoren Instrumente Systeme GmbH
Mühlenkoppel 12, D-24222 Schwentinental, Germany
Tel.: +49-431-79972-0
Fax: +49-431-79972-11
Email: info@sis-germany.com
WWW: <http://www.sis-germany.com>